

Import Belgium & Luxembourg

Profilex s.a.

4A, Z.I. In den Allern Tel: 00352/99 89 06
L-9911 Troisvierges Fax: 00352/26 95 73 73

www.profilex-systems.com

profilex@pt.lu

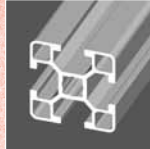

SPECIAL EXTRUSIONS
AND ACCESSORIES

PROFILE 30 X 30

Part. N° 20.1068/0

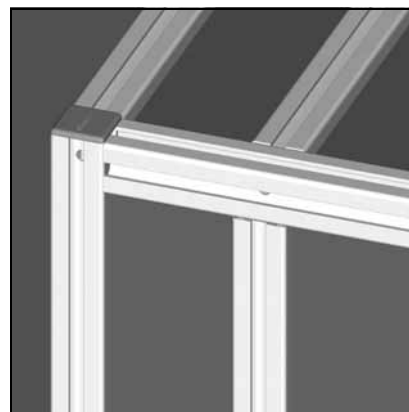
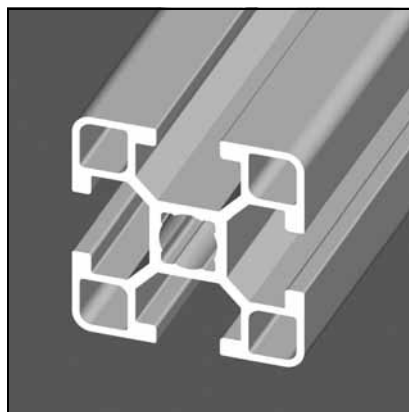
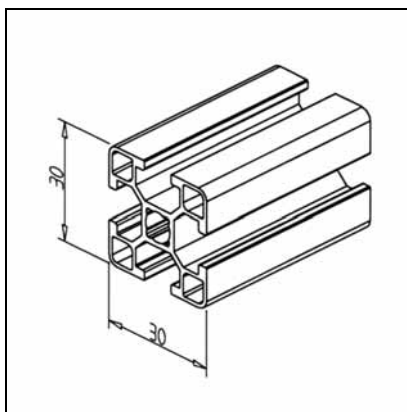

TECHN. DATA / ITEMS SUPPLIED

- lx =	2,133 cm ⁴
- ly =	2,133 cm ⁴
- wx =	1,422 cm ³
- wy =	1,422 cm ³
- Weight	0,641 kg/m
- Length	6 m

APPLICATIONS

- Light structures, holders, protective devices
- Suitable end-cap: Part. N° 22.1035/1

ASSEMBLY

- MiniTec Power-lock Fastener 30, Part. N° 21.0014/0
- Screw connection 30 N Part. N° 21.1385/0
- Angle 30 GD Part. N° 21.1347/0
- Attached parts can be fastened using MiniTec square nuts 30 or rhombus nuts F M6, Part. N° 21.1354/0

MINITEC POWER-LOCK FASTENER 30

Part. N° 21.0014/0

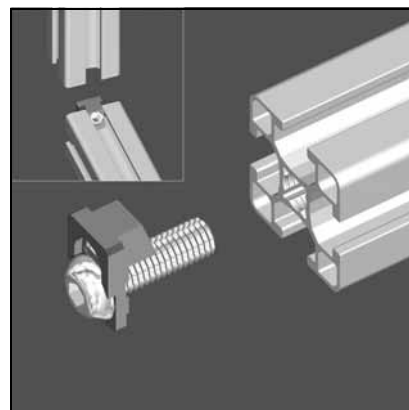
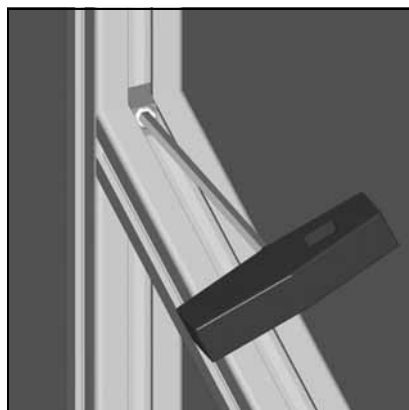
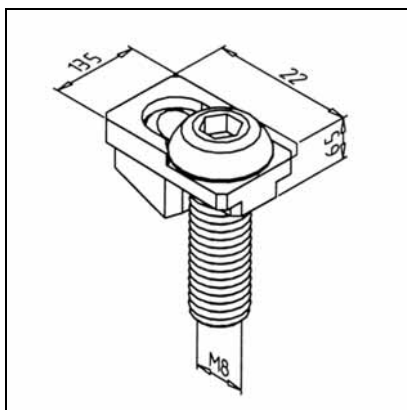

TECHN. DATA / ITEMS SUPPLIED

- 1 connecting element, zinc plated	
- 1 fillister head screw M8 x 25, galvanized	
- Weight	0,029 kg

APPLICATIONS

- Power-lock connection for profiles series 30
- Also suitable for cross joints

ASSEMBLY

- Mount fastener onto profileface
- Tighten set screw M8 with key SW 4
- Recommended locking torque 12 Nm

SCREW-CONNECTION 30 N

Part. N° 21.1385/0

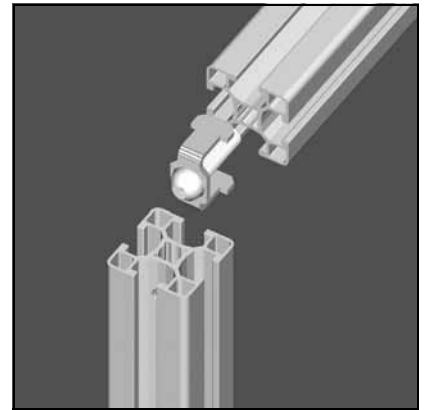
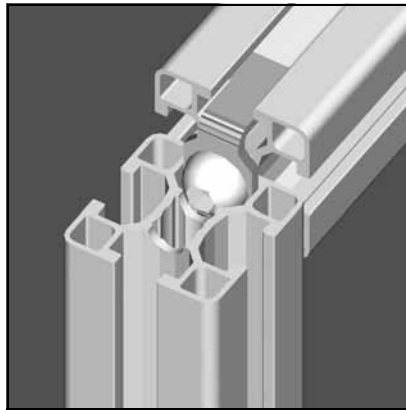
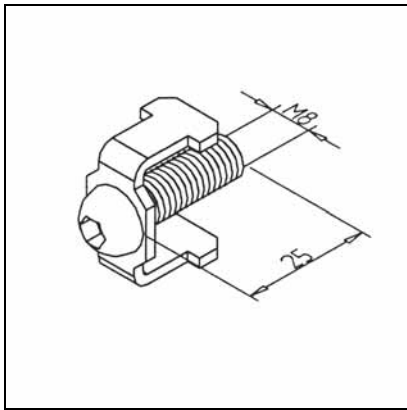

TECHN. DATA / ITEMS SUPPLIED

- Screw M8 x 25, zinc plated
- Locking device steel, zinc plated
- Weight 0,170 kg

APPLICATIONS

- Connection of profiles 30 x 30

ASSEMBLY

- Form thread M8 x 25 into the profile to be fixed
- Bore through hole Ø 7 into second profile
- Preassemble screw and locking device, slide down profile 1 and position behind bore
- Tighten the screw
- Recommended locking torque: 20 Nm

END CAPS 30 X 30

Part. N° 22.1035/1

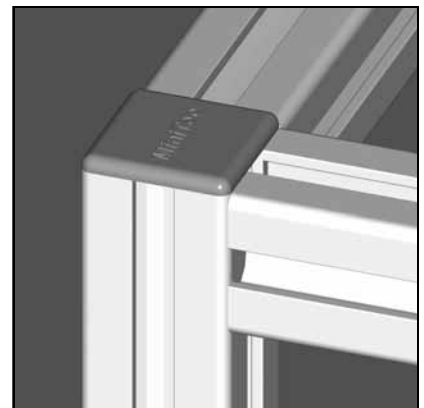
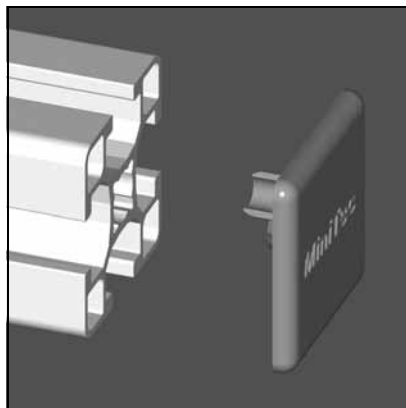
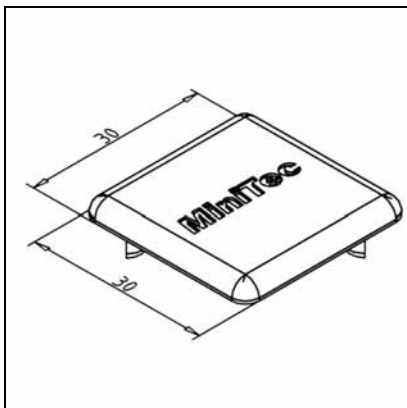

TECHN. DATA / ITEMS SUPPLIED

- ABS, grey, non aging, oil-resitant
- Thickness 3 mm

APPLICATIONS

- Cut off face covering of profiles

ASSEMBLY

- Press on cut-off face

ANGLE 30 GD

Part. N° 21.1347/0

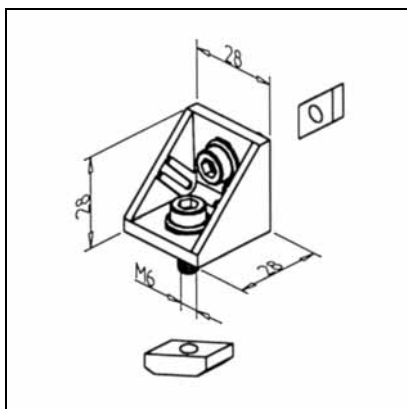

TECHN. DATA / ITEMS SUPPLIED

- Aluminium GD, powder coated, grey
- Fastening kit
- Weight 0,065 kg

APPLICATIONS

- Constructions made from profile 30 x 30, subsequent insertion of profiles or components into existing constructions
- Fixing of panels, table-tops
- Reinforcement of constructions made from profile 30 x 30

ASSEMBLY

- Use fastening kit
- Recommended locking torque: 8 Nm
- Suitable end cap: Part. N° 22.1026/1

SQUARE-NUT 30

Part. N°

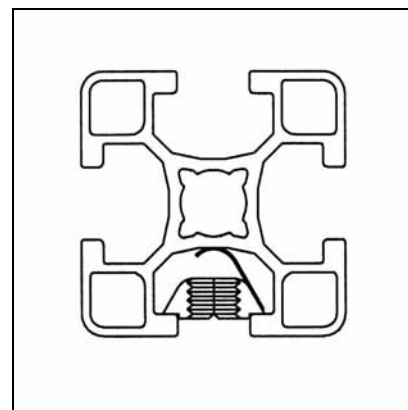
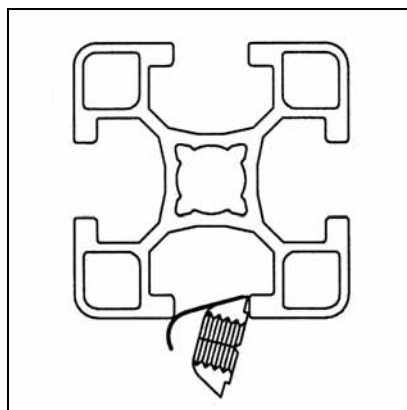
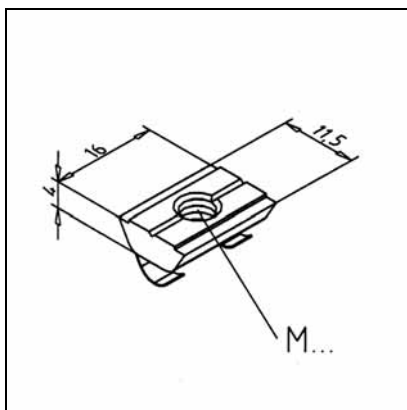

TECHN. DATA / ITEMS SUPPLIED

- Steel, zinc plated
- Weight M4 0,0042 kg
- Weight M5 0,0038 kg
- Weight M6 0,0032 kg
- Weight M8 0,0026 kg

APPLICATIONS

- Fastening of accessories and system components onto profiles 30x30

ASSEMBLY

- Insertion into the profile groove
- Variants:
- M4 Part. N° 21.1567/0
- M5 Part. N° 21.1568/0
- M6 Part. N° 21.1569/0
- M8 Part. N° 21.1570/0

HINGE L 19/30

Part. N° 21.1374/0

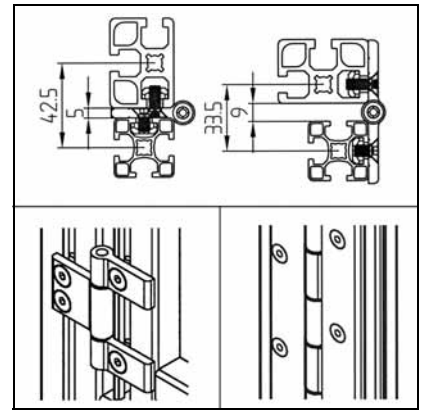
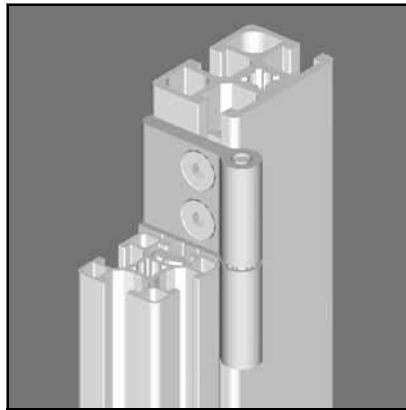
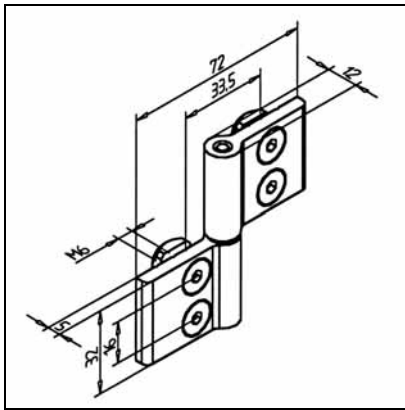

TECHN. DATA / ITEMS SUPPLIED

- Aluminium, natural anodized, steel cylinder-bolt
- Fastening kit
- End caps
- Weight 0,089 kg
- Load max. 400 N

APPLICATIONS

- Doors, lids, movable attached constructions
- According to arrangement lift removable or non-lift-removable
- Connection of profiles 19 and 30 at various angles

ASSEMBLY

- Use fastening kit
- For production of hinges in various length or bore distances or piano-hinges extrusion Part. N° 20.1076/0 is available

HINGE L 30/30

Part. N° 21.1376/0

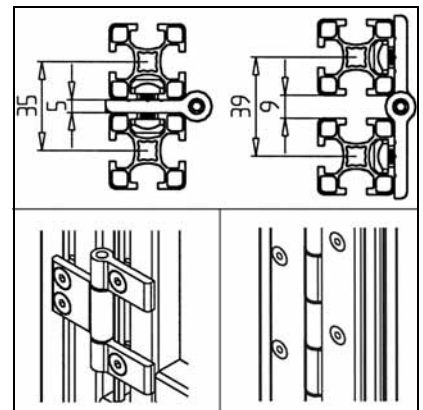
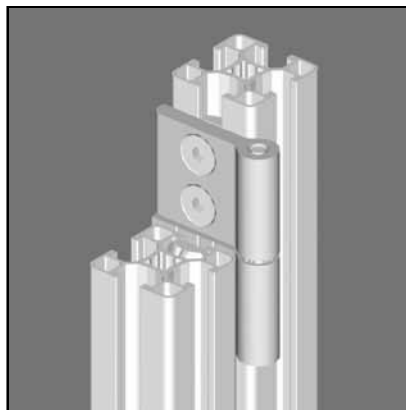
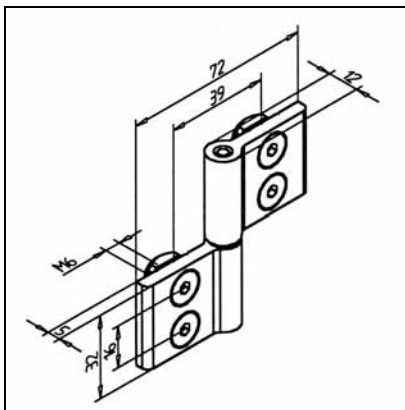

TECHN. DATA / ITEMS SUPPLIED

- Aluminium, natural anodized, steel cylinder-bolt
- Fastening kit
- End caps
- Weight 0,089 kg
- Load max. 400 N

APPLICATIONS

- Doors, lids, movable attached constructions
- According to arrangement lift removable or non-lift-removable
- Connection of profiles 30 at various angles

ASSEMBLY

- Use fastening kit
- For production of hinges in various length or bore distances or piano-hinges extrusion Part. N° 20.1076/0 is available

HINGE L 30/45

Part. N° 21.1377/0

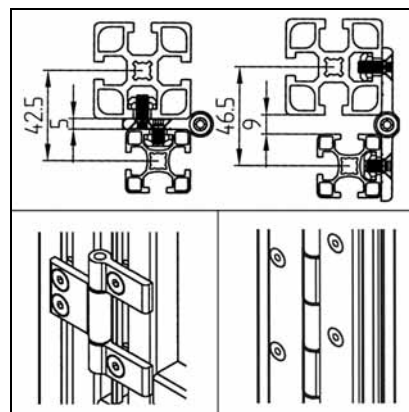
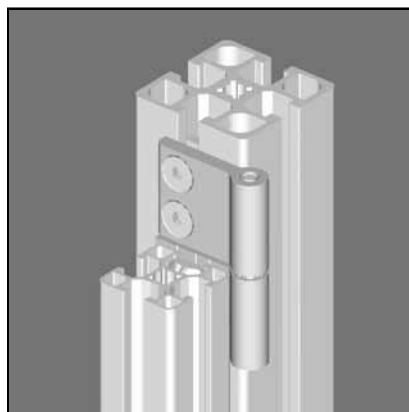
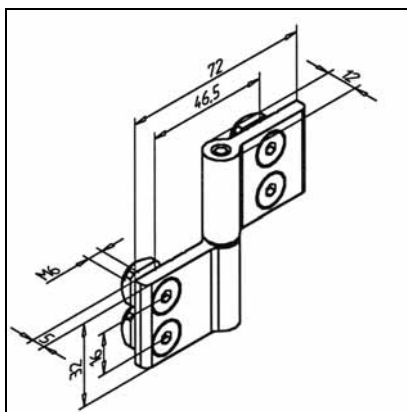

TECHN. DATA / ITEMS SUPPLIED

- Aluminium, natural anodized, steel cylinder-bolt
- Fastening kit
- End caps
- Weight 0,089 kg
- Load max. 400 N

APPLICATIONS

- Doors, lids, movable attached constructions
- According to arrangement lift removable or non-lift-removable
- Connection of profiles 30 and 45 at various angles

ASSEMBLY

- Use fastening kit
- For production of hinges in various length or bore distances or piano-hinges extrusion Part. N° 20.1076/0 is available

INSERT SEAL 4-30

Part. N° 22.1105/0

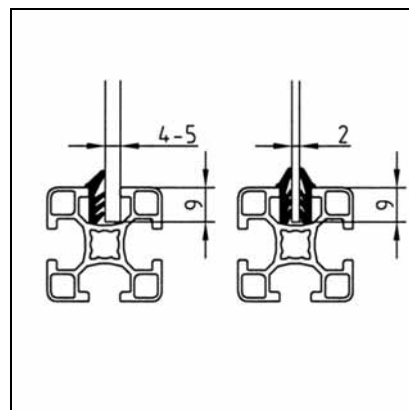
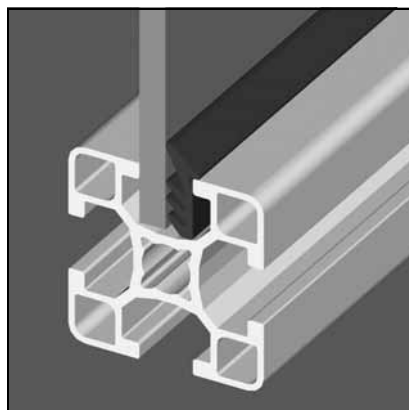
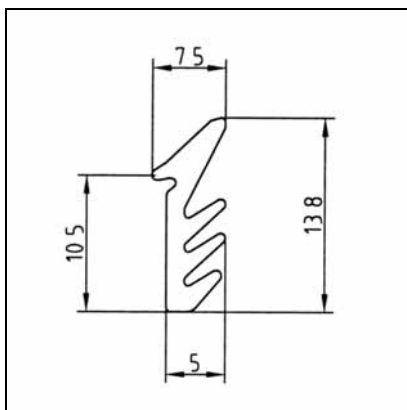

TECHN. DATA / ITEMS SUPPLIED

- EPDM-AGV, black
- Weight 0,041 kg/m
- Length max. 200 m

APPLICATIONS

- Attachment and sealing of panel elements up to 4 - 5 mm in the profile groove
- For profile 30 x 30

ASSEMBLY

- Insert panel element into profile groove and press insert seal subsequently into free space between panel element and profile groove with blunt tool made of wood or plastic
- For panels < 2 mm mount additional insert seal
- Allow an enlargement of panel elements in x and y direction of: +18 mm

PROFILE 19 X 11

Part. N° 20.1074/0

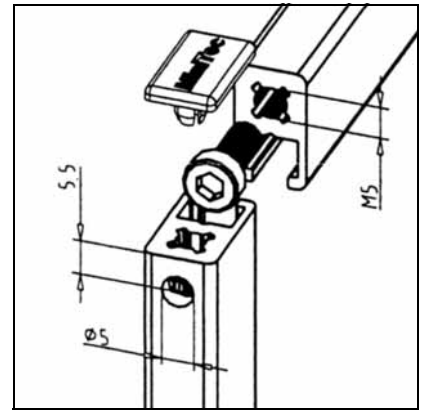
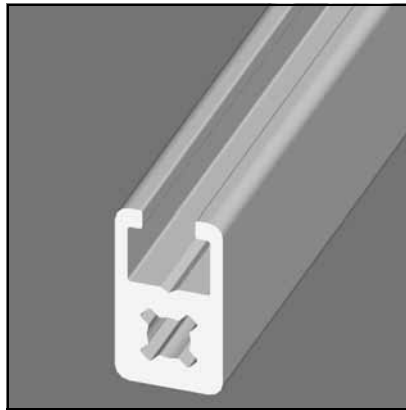
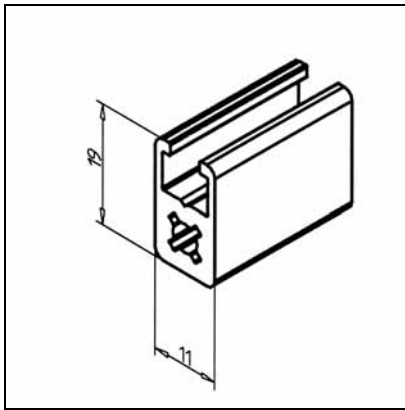

TECHN. DATA / ITEMS SUPPLIED

- lx =	0,327 cm ⁴
- ly =	0,166 cm ⁴
- wx =	0,287 cm ³
- wy =	0,302 cm ³
- Weight	0,326 kg/m
- Length	6 m

APPLICATIONS

- Small guards and constructions
- Suitable end cap: Part. N° 22.1030/1

ASSEMBLY

- Screw connection 11, Part. N° 21.1574/1

PROFILE 19 X 19

Part. N° 20.1075/0

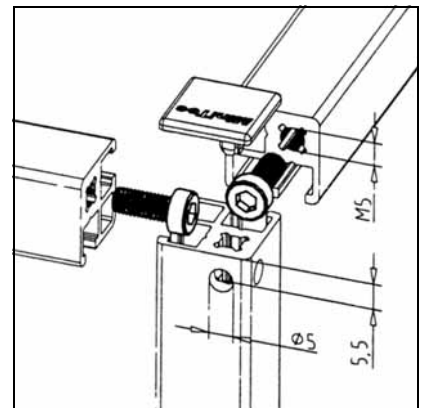
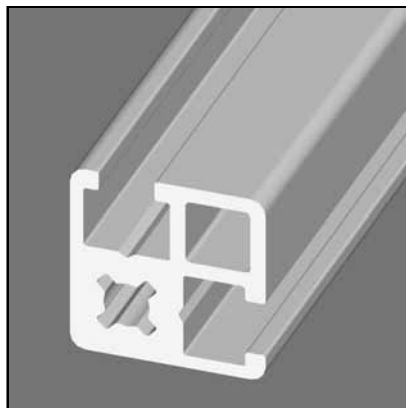
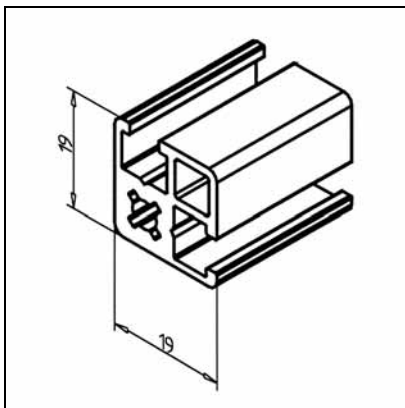

TECHN. DATA / ITEMS SUPPLIED

- lx =	0,570 cm ⁴
- ly =	0,570 cm ⁴
- wx =	0,543 cm ³
- wy =	0,543 cm ³
- Weight	0,460 kg/m
- Length	6 m

APPLICATIONS

- Small guards and constructions
- Suitable end cap: Part. N° 22.1031/1

ASSEMBLY

- Screw connection 11, Part. N° 21.1574/1

SQUARE-NUT M05 X 8

Part. N° 21.1382/0

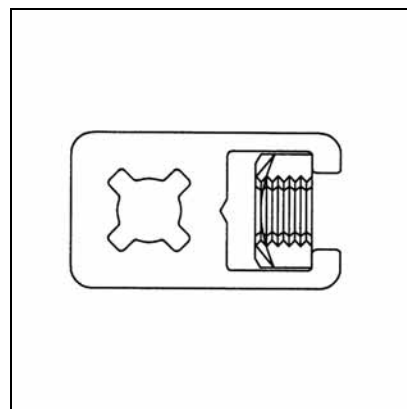
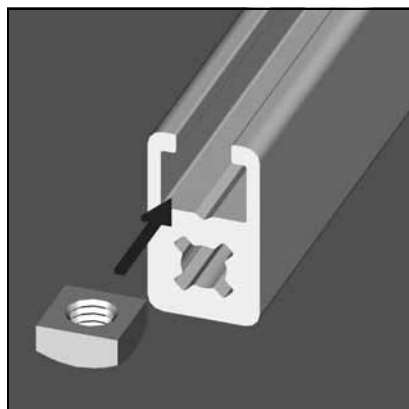
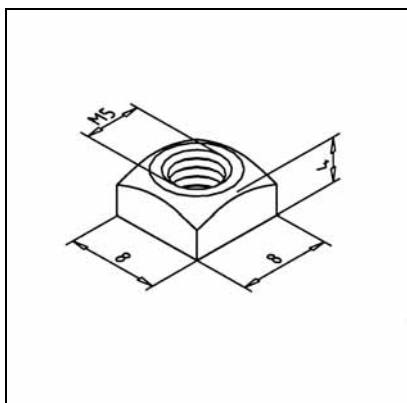

TECHN. DATA / ITEMS SUPPLIED

- Steel, zinc plated

- Weight 0,001 kg

APPLICATIONS

- Fastening of accessories and system components onto profiles 19x11 and 19x19

ASSEMBLY

- Enter square nut from profile end

END CAPS

Part. N°

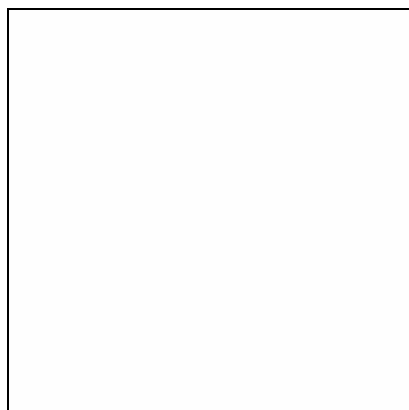
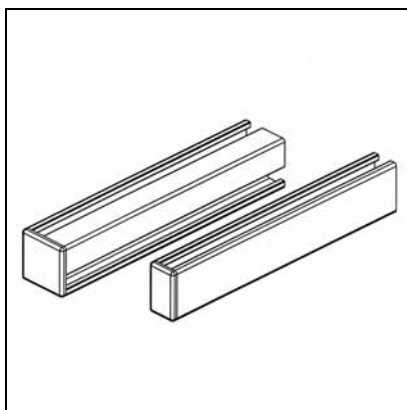

TECHN. DATA / ITEMS SUPPLIED

- ABS, grey, non-aging, oil-resistant

- Thickness for profile 19 x 11 and 19 x 19 2 mm

APPLICATIONS

- Cut-off face covering of profiles

ASSEMBLY

- Press on cut-off face

- For profile 19 x 11 Part. N° 22.1030/1

- For profile 19 x 19 Part. N° 22.1031/1